

**OXFORD BOROUGH
APPLICATION AND PERMIT FOR OPENING AND
EXCAVATION OF BOROUGH STREETS**

DATE: _____

APPLICANT: _____

ADDRESS: _____

EXACT LOCATION OF PROPOSED OPENING OR EXCAVATION AND APPLICABLE DRAWINGS:

PURPOSE: _____

APPROXIMATE AREA TO BE DISTURBED IN SQUARE YARDS: _____

It is hereby agreed that all work shall be done in full compliance with the ordinances of the Borough of Oxford and the laws and regulations of the Commonwealth in relation thereto.

It is further agreed that I/We shall well and truly save, defend and keep harmless the Borough, its agents and assigns, from and indemnify them against any and all actions, suits, demands, payments, costs and changes for or by reason of the proposed opening or excavation, and all damages to any person or property resulting in any manner there from, or occurring in the prosecution of the work connected herewith, or from any other matter, cause or thing relating thereto; and that I/We will be responsible for maintenance of the portion of the street disturbed by such opening or excavation, and the restored surface thereof, for a period of one year following the restoration and completion of the work for which such opening or excavation was made.

All necessary and reasonable precautions will be taken to keep the street in a safe and passable condition both day and night by the placement of barriers, guards, warning lights and signs.

Applicant's signature, printed name and title

FEE: _____
(\$100 minimum. Additional \$10 per SY of disturbed area over 5 SY)

CONDITIONS:

- The permit application must be accompanied by two sets of engineered drawings for review and comment by the Borough's engineers. A detailed description of the scope of work is also necessary.
- The cost of the permit, any inspection costs and the cost for the engineer's review will be collected at the time the application is accepted.
- If there is to be any encroachment onto any private property adjacent to the Borough's right-of-way, copies of signed easements from the property owners must also be included with the application.
- Trench backfill and restoration shall be in accordance with the attached details and with any additional requirements stipulated herein.

Received and Approved By: _____ Date _____

Borough Manager

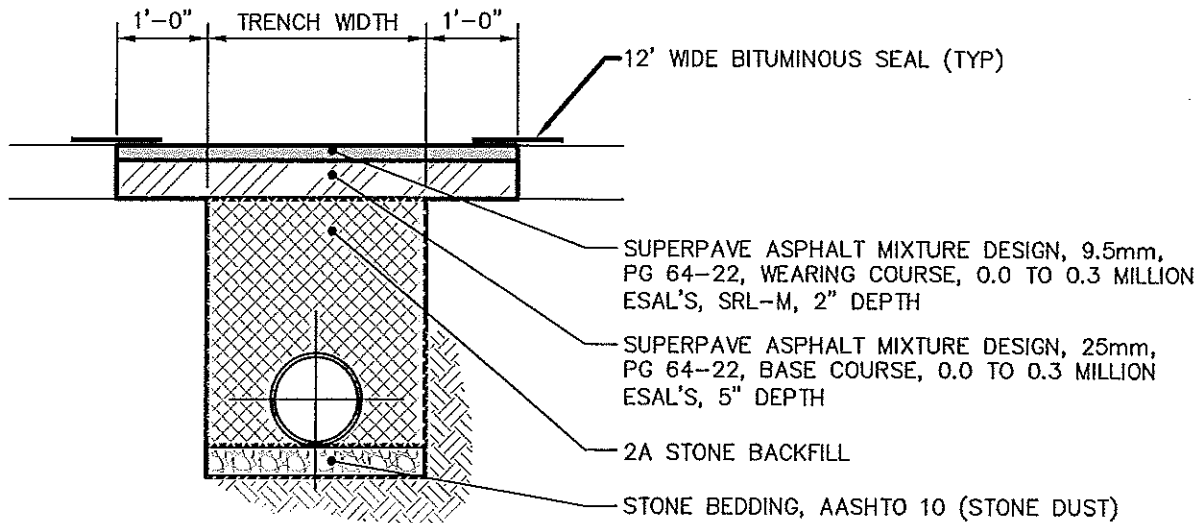

BITUMINOUS PAVING – PERMANENT RESTORATION

NOTES :

1. BASE COURSE DEPTH SHALL BE 6" ON COLLECTOR ROADS.
2. ESAL CATEGORY FOR COLLECTOR ROADS SHALL BE DETERMINED BY THE BOROUGH ENGINEER ON A CASE BY CASE BASIS.
3. SRL CATEGORY FOR COLLECTOR ROADS SHALL BE DETERMINED BY THE BOROUGH ENGINEER ON A CASE BY CASE BASIS.

FOR TRENCH WIDTH AND BACKFILL MATERIALS SEE SHEET A.001

RELEASED FOR: INFORMATION <i>NOT FOR CONSTRUCTION</i>	BOROUGH of OXFORD STANDARD DETAIL	03/17/11 <small>DATE</small>	100659.2011 <small>g.002</small> <small>DIGITAL FILENAME</small>
	OXFORD BOROUGH, CHESTER COUNTY, PENNSYLVANIA	100659.2011	
<small>PROJECT MANAGER: C.F.F. DATE: 03/17/11</small> <small>BASE BY: N/A/ N.B.: N/A</small> <small>DRAWN BY: G.J.C. DESIGNED BY: M.S. CHKD: C.F.F.</small>	PERMANENT MUNICIPAL ROAD RESTORATION	<small>WORK ORDER NUMBER</small>	
LEHIGH VALLEY 610.849.9700 F. 610.849.9701 READING 610.621.2000 F. 610.621.2001	 SSM <small>SSM Group, Inc.</small>	A.002	
COPYRIGHT 2011 SPOTTS, STEVENS AND McCOY, INC.		<small>DRAWING NUMBER</small>	

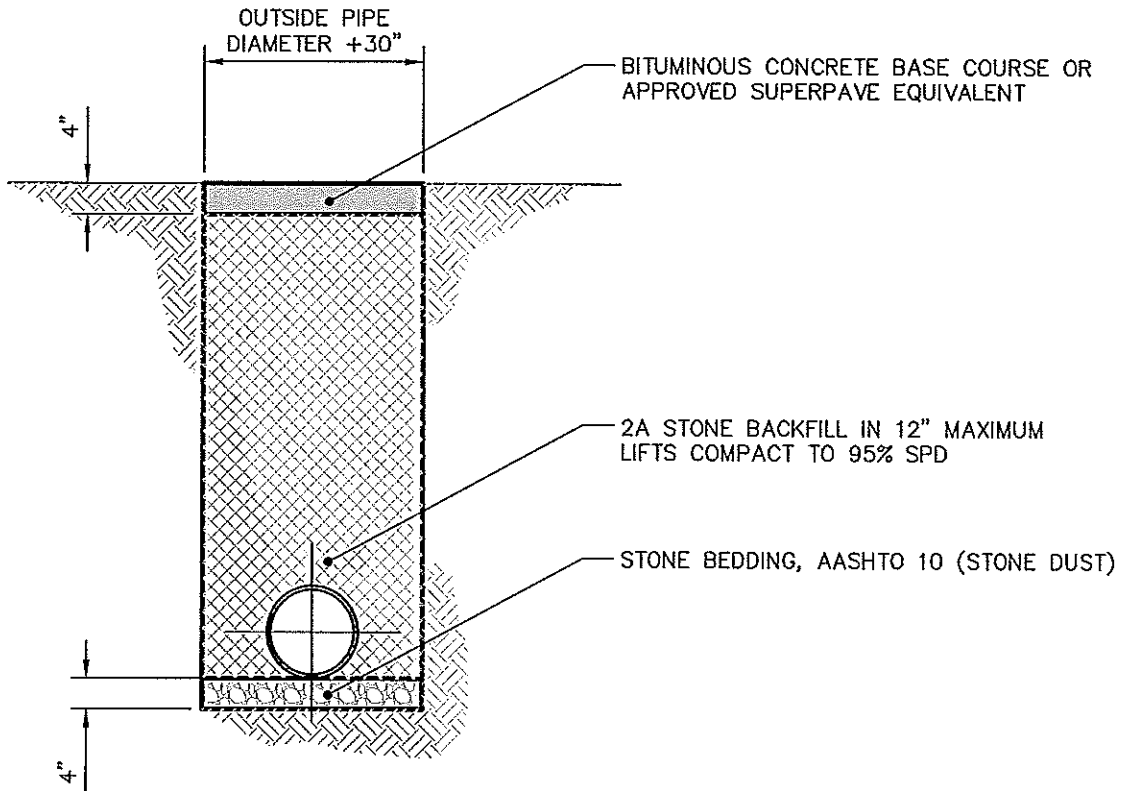

PAVED STREET TEMPORARY RESTORATION

RELEASED FOR: INFORMATION <i>NOT FOR CONSTRUCTION</i>	BOROUGH of OXFORD STANDARD DETAIL OXFORD BOROUGH, CHESTER COUNTY, PENNSYLVANIA TEMPORARY MUNICIPAL ROAD RESTORATION	<table border="1" style="width: 100%; border-collapse: collapse;"> <tr> <td style="width: 50%;">03/17/11</td> <td style="width: 50%;">100659.2011</td> </tr> <tr> <td style="font-size: small;">DATE</td> <td style="font-size: small;">DIGITAL FILENAME</td> </tr> <tr> <td colspan="2" style="text-align: center; font-size: large; font-weight: bold;">100659.2011</td> </tr> <tr> <td colspan="2" style="font-size: x-large; font-weight: bold; text-align: center;">A.001</td> </tr> <tr> <td colspan="2" style="font-size: x-small; text-align: center;">DRAWING NUMBER</td> </tr> </table>	03/17/11	100659.2011	DATE	DIGITAL FILENAME	100659.2011		A.001		DRAWING NUMBER	
03/17/11	100659.2011											
DATE	DIGITAL FILENAME											
100659.2011												
A.001												
DRAWING NUMBER												
PROJECT MANAGER: C.F.F. DATE: 03/17/11 BASE BY: N/A/ N.B.: N/A DRAWN BY: G.H.C. DESIGNED BY: M.S. CHKD: C.F.F.												
LEHIGH VALLEY 610.849.9700 F. 610.849.9701 READING 610.621.2000 F. 610.621.2001	 SSM SSM Group, Inc.	COPYRIGHT 2011 SPOTTS, STEVENS AND McCOY, INC.										

Oxford Borough
Escrow Form
Attachment to Road Opening Permit

Total Engineering Fees:

Estimate: _____ Received: \$ _____

Date Received: _____

Check #: _____

Applicant' Signature: _____

Borough Manager: Approve _____

Yes

No

Signature: _____ Date: _____

Other escrow funds collected: (Explain) _____

Total Escrow Funds Received: _____

Length of Time To Be Held: _____

Additional Comments: _____
